

# **Cutting-Edge Practices in Hitachi**

# A framework for Env. Data Management System

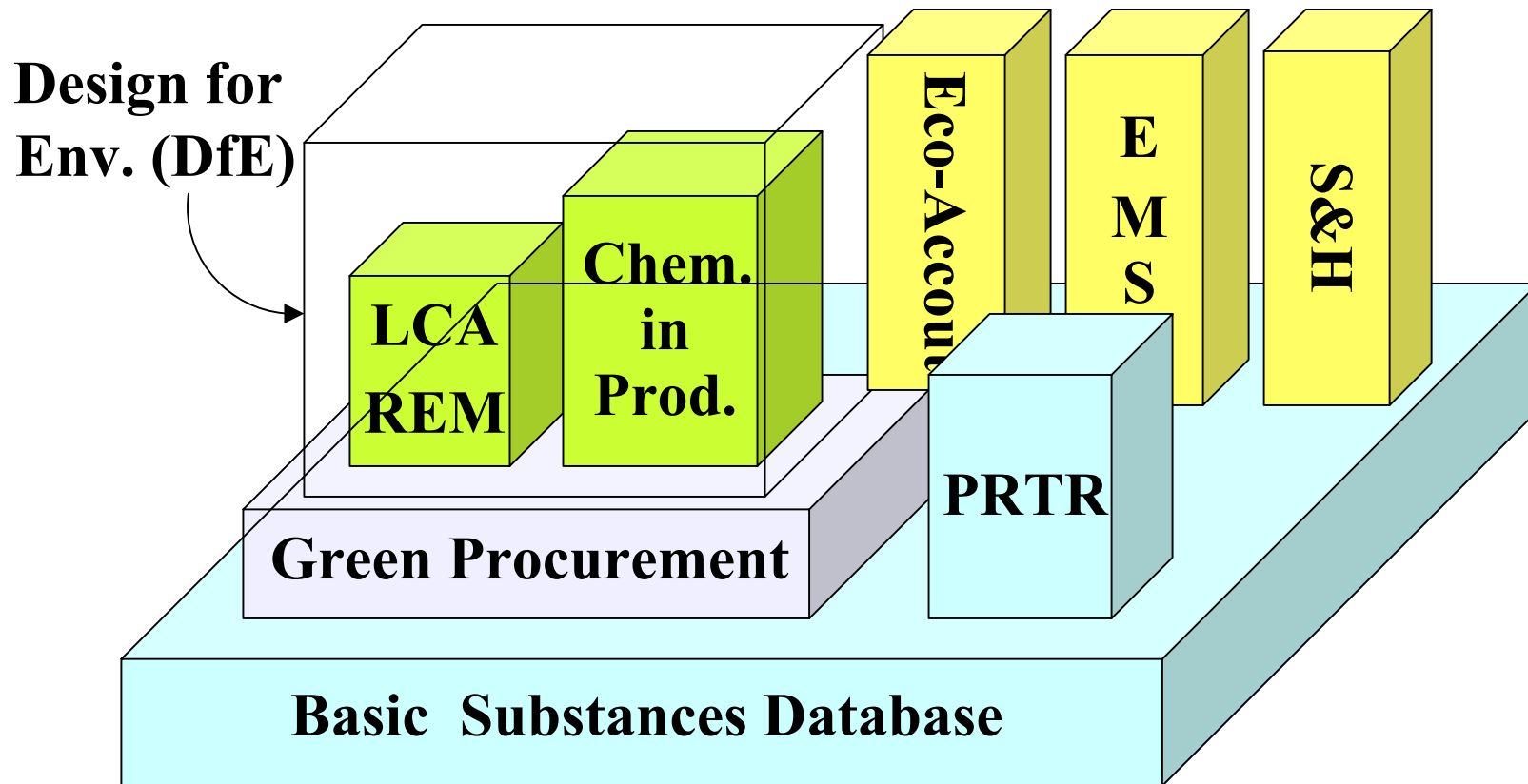

LCA: Life Cycle Assessment, REM: Recyclability Evaluation Method,  
EMS: Environmental Management System, PRTR: Pollutant Release and Transfer Register  
S&H: Safety and Health

# Typical Structure in Business Corporation

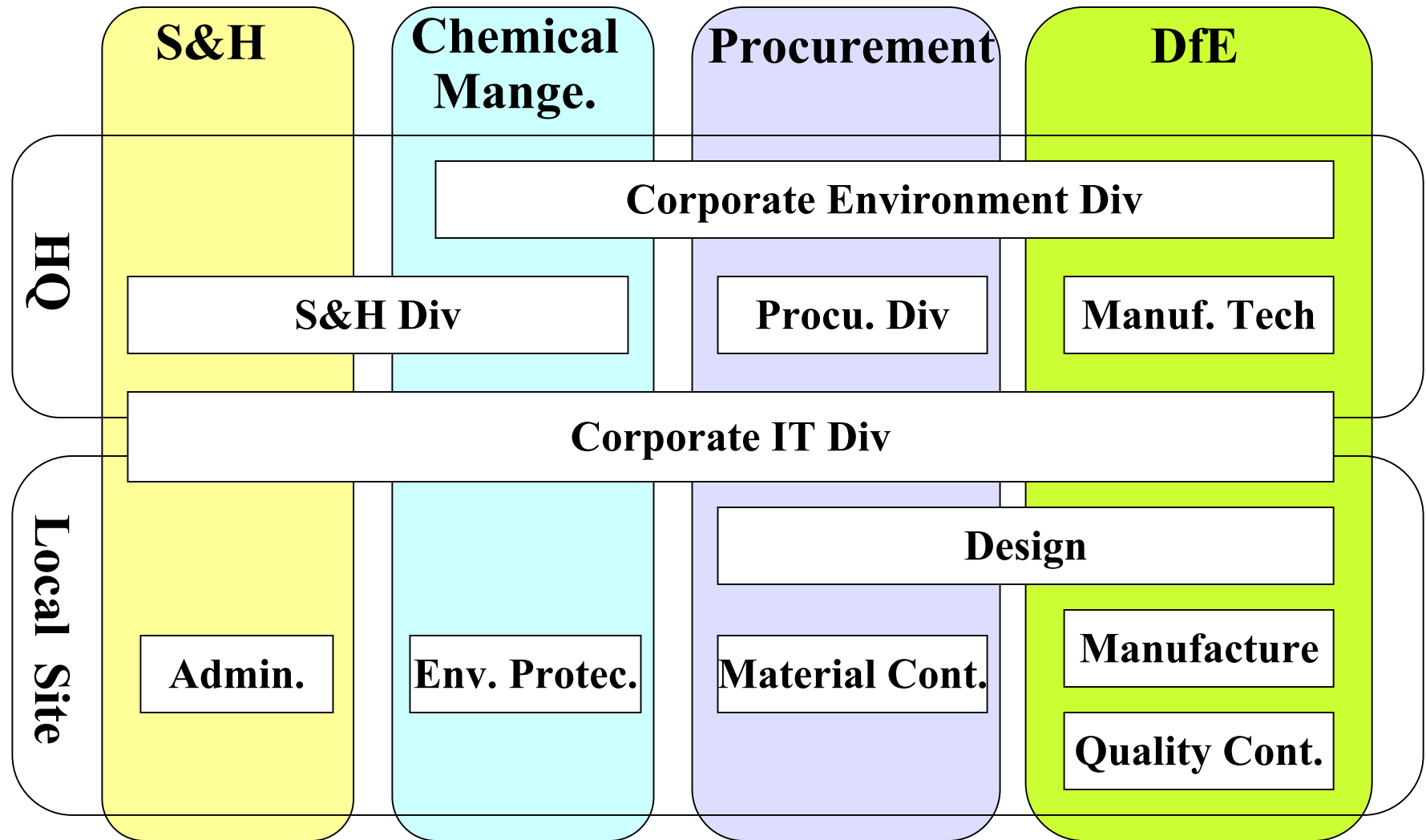

# Strategy for Building Total Management System

- 1** Initiate a corporate level project which intersects vertical structures of business tasks and charges.
- 2** Build a shared database of substances, which can be a foundation of all the environmental tasks, including chemical management, safety and health management, etc.
- 3** Build a shared database for purchased parts/materials and establish green procurement operations and tasks.
- 4** Establish a business operation structure to respond quickly to the requirement of customers by automatically evaluating recycling rate, chemicals in products, and conducting LCA.

# IT Systems Concept for Env. Management

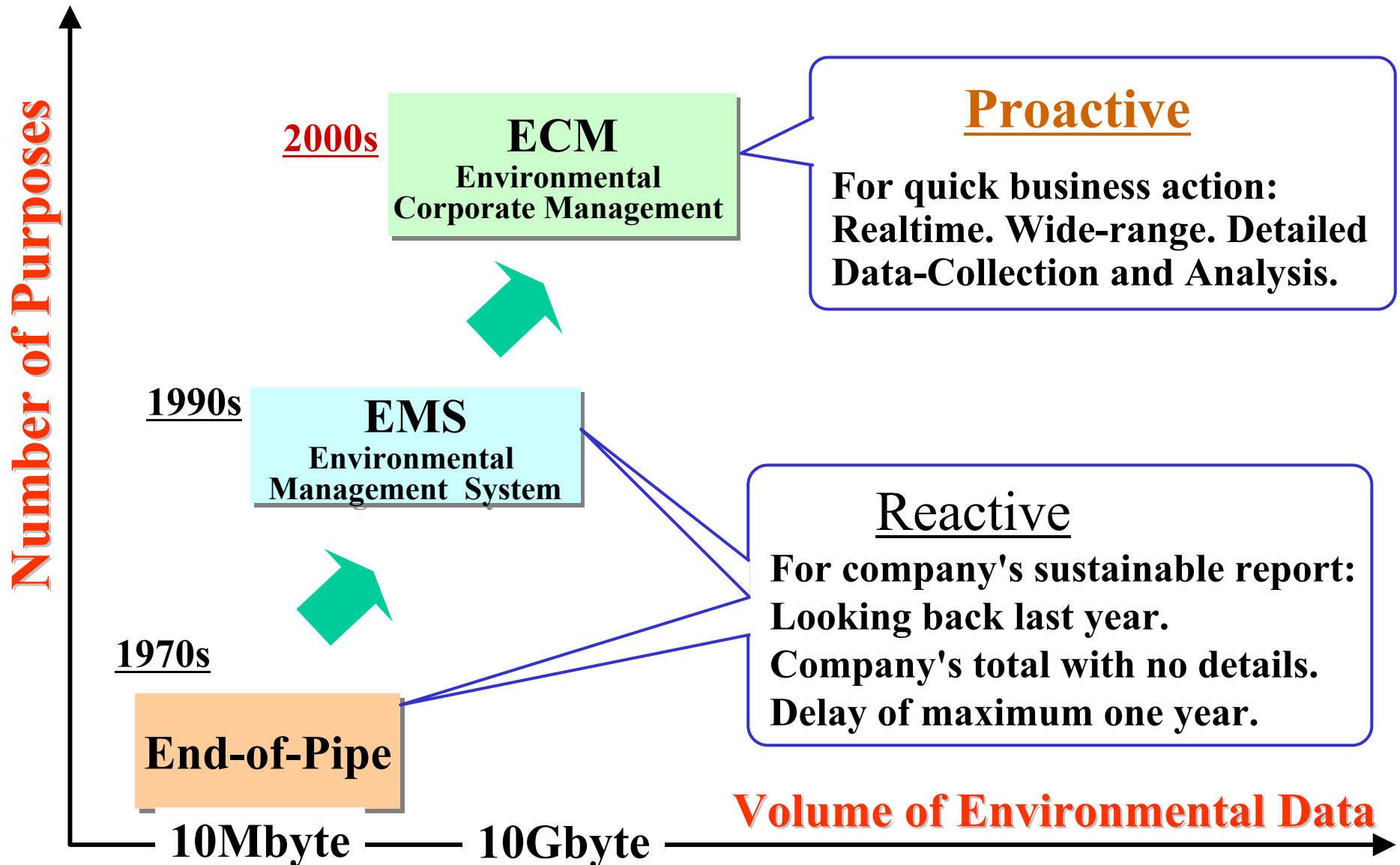

## Orders of the Data to Process (EPI)

		1970	2000
Samples per year		12 (monthly)	12 (monthly)
Data retention period		10 years	10 years
Resolution	Organizations	10 (major sites)	100 (all sites)
	Sub organizations	none	10 (div., prod. line)
	Number of data	100 (end of pipe)	1000 (multi-purpose)
Bytes per data		128 (numeric)	256 (numeric and description)
Total		15Mbyte	30Gbyte

EPI : Environmental Performance Index

# Data Sharing Among Multiple Tasks

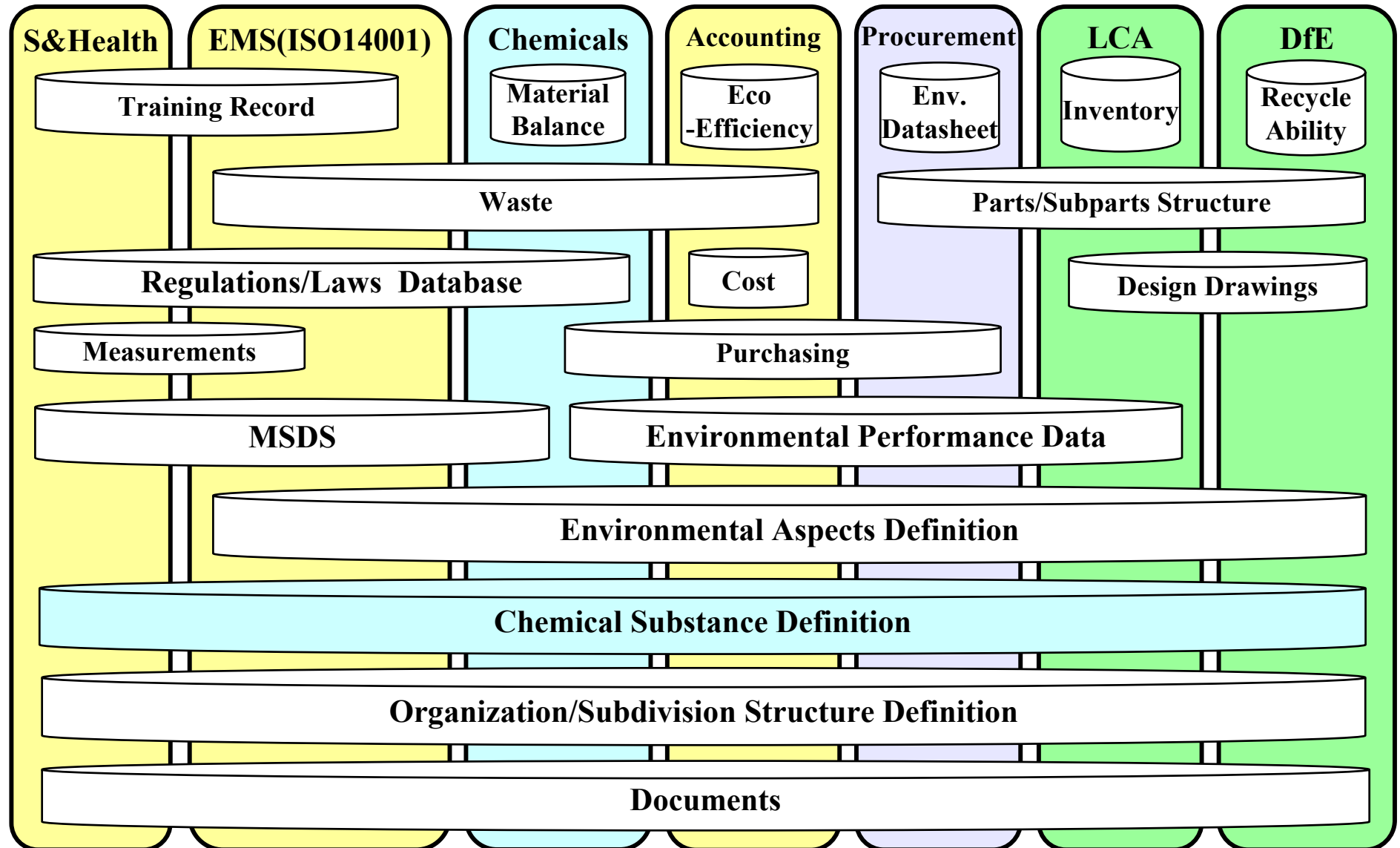

# Chemical Management and its Basic Data

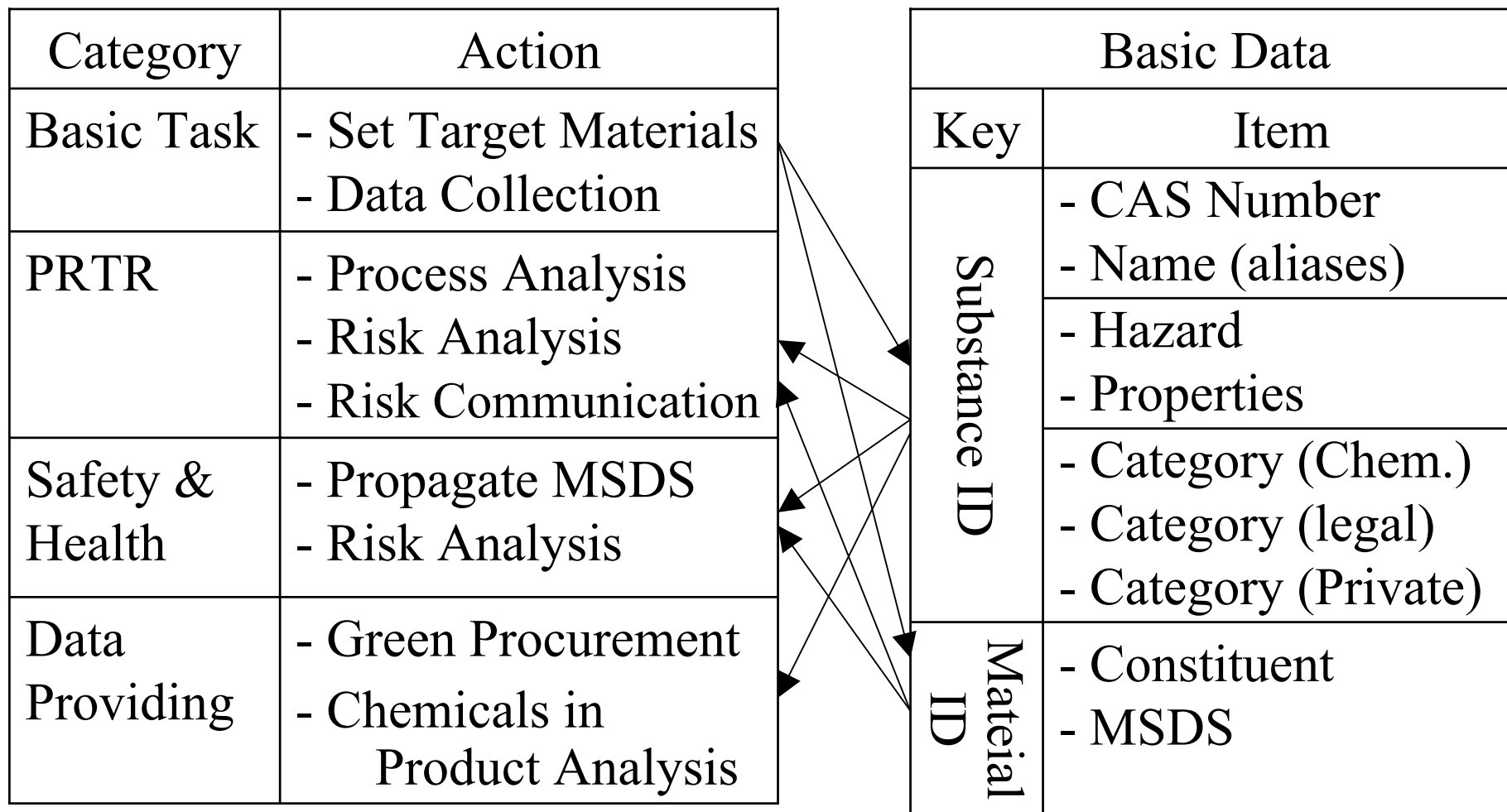

# Types and volumes of Chemical Management Data

Case of a typical assembler type downstream user site

Type		Volume
Basic	Substance ID	10,000
	Legal Catego.	PRTR, TSCA, Unti-pollution, 10 categories
	Material ID	50,000
Operation	Time Frame	365 days * 10 years
	Processes	10 / site * 100 sites
	Purchased Materials	100 items / site including solvent, paint, adhesive, sealer, etc.,
	Substance over 1 ton/year	10 substances / site mainly VOCs

# Systematize with Databases

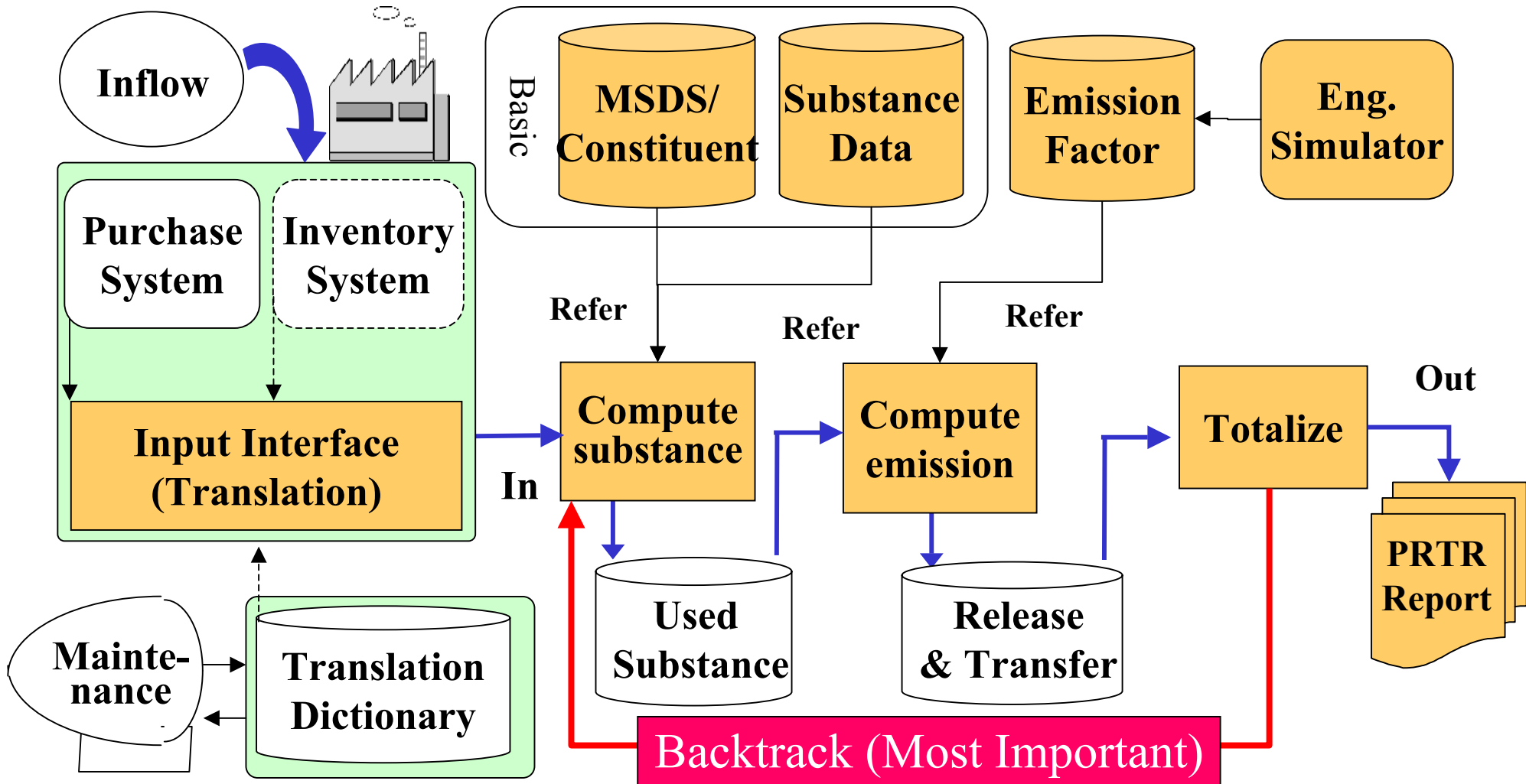



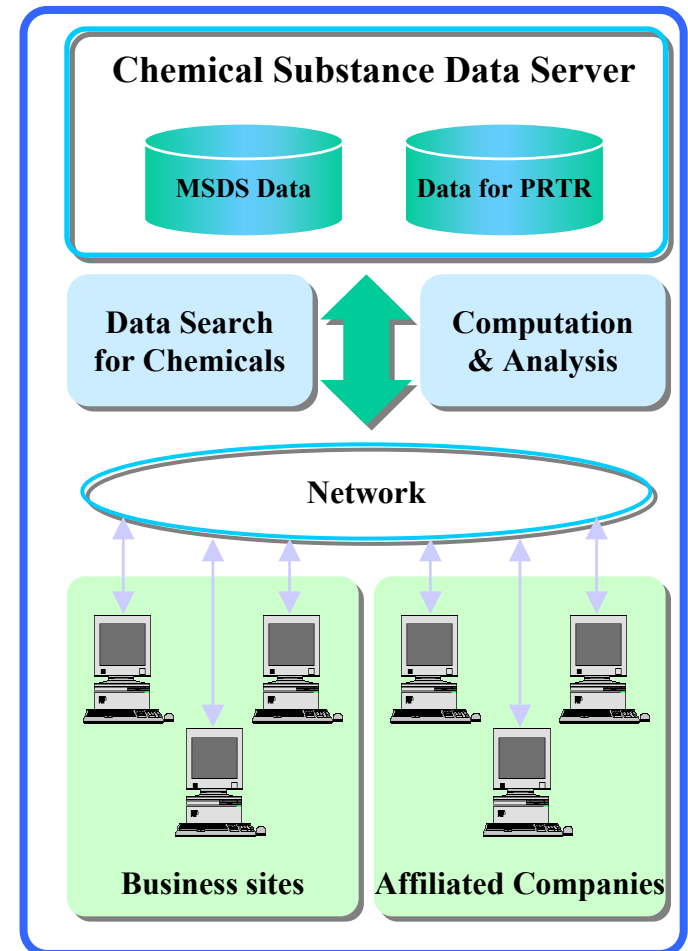
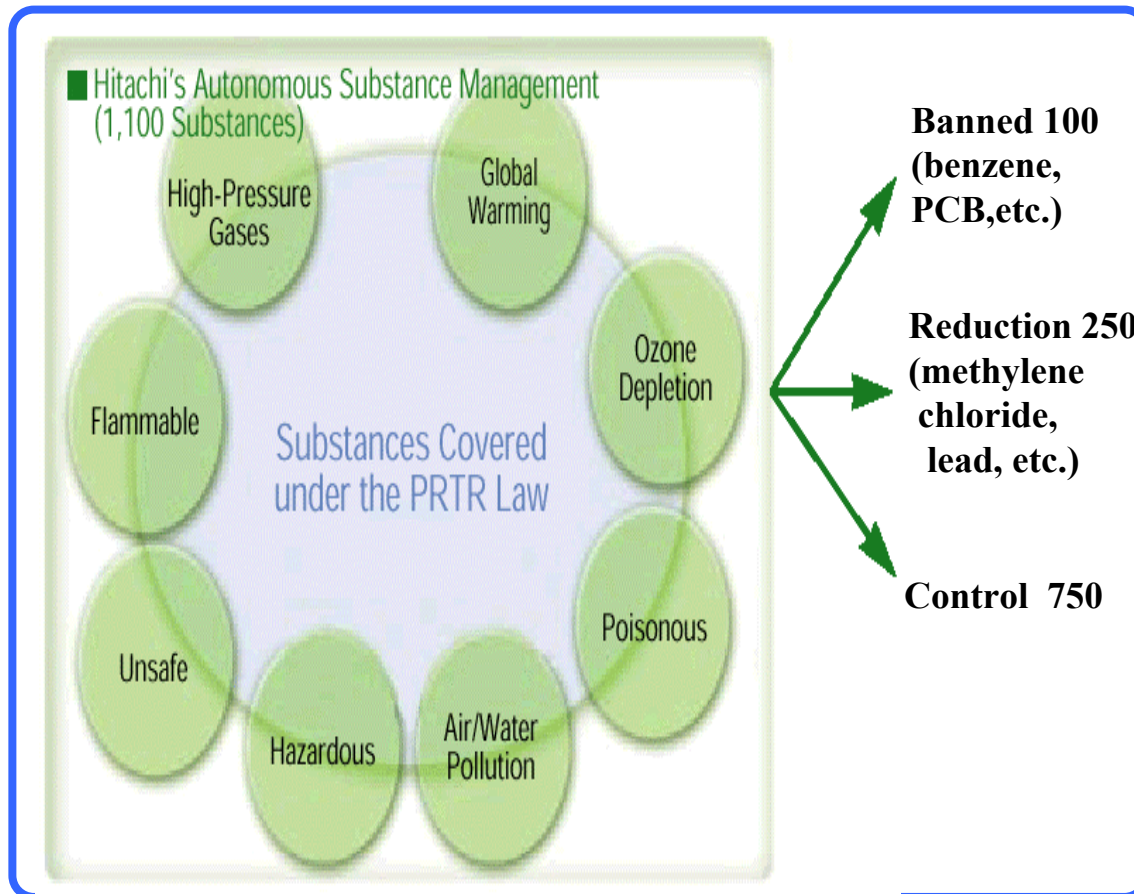

# Chemical Management System in Hitachi











## 基本データベースの物質定義の例





物質名	CASNo	PRTR法 (第1種) 対象-No.	水質汚濁 防止法 対象-No.	毒物劇物 取締法 対象-No.	化審法(第 二種) 対象-No.	埼玉県 特定 化学物質 対象-No.
1,2-ジカルバ-closo-ドデカボラン	16872-09-6	○-304	○-582	-	-	-
1,2-ジクロロ-1,1,2,2-テトラフルオロエ	76-14-2	○-123	-	-	-	○-630107
1,2-ジクロロ-1,1,2-トリフルオロエタン	354-23-4	-	○-1272	-	-	-
1,2-ジクロロ-3-ニトロベンゼン	3209-22-1	○-127	-	-	○-414	○-080801
1,2-ジクロロエタン	107-06-2	○-116	○-424	-	○-005	○-260607
1,2-ジクロロエチレン	540-59-0	-	-	-	-	-
1,2-ジクロロプロパン	78-87-5	○-135	-	-	○-011	○-260608
1,2-ジフェノキシエタン	104-66-5	-	-	-	○-160	-
1,2-ジフルオロベンゼン	367-11-3	-	○-1280	-	-	-
1,2-ジブromo-3-クロロプロパン	96-12-8	-	-	○-382	-	○-260901
1,2-ジブromoエタン	106-93-4	-	-	○-378	-	○-260702
1,2-ジメチルヒドラジン	540-73-8	-	-	-	-	○-270203
1,2-ビス(3,4-ジメチルフェニル)エタン	34101-86-5	-	-	-	○-088	-
1,2-ブチレンオキシド	106-88-7	-	-	-	-	○-040201
1,3,2-ジオキサチオラン=2-オキシド	HCAS00540	-	-	-	○-621	-
1,3,5,7-(テトラメチル)シクロテトラシロキ	HSC800086	-	-	-	○-291	-
1,3,5-トリグリシジルイノシアヌル酸	2451-62-9	○-218	-	-	-	○-200201
1,3,5-トリリス(2,3-エポキシ-2-メチルプロ	HCAS00497	-	-	-	○-568	-
1,3-シクロヘキサジエン	592-57-4	-	-	-	○-540	-
1,3-ジオキサ-2-スチバシクロペンタン	4933-27-1	○-25	-	○-722	-	-
1,3-ジカルバモイルチオ-2-(N,N-ジメチル)	15263-53-3	-	-	○-694	-	-
1,3-ジクロロ-1,2,2,3,3-ペンタフルオロ	507-55-1	○-144	-	-	-	○-680121

## Sample of Substance Definition (Screen Page)

No. 対象  物質名 p-オクチルフェノール  
 CAS No. 1806-26-4  
59 ○  キーワード 4-オクチルフェノール \$ P-OCTYLPHENOL \$ P-オクチルフェノール \$ 4-OCTYLPHENOL \$ 4-(N-OCTYL)PHENOL  
 金属換算率 1

No. 対象  物質名 カドミウム及びその化合物  
 CAS No. NONE  
60 ◎  キーワード CADMIUM AND ITS COMPOUNDS \$ カドミウム及びその化合物  
 金属換算率 1

No. 対象  物質名 ぎ酸カドミウム  
 CAS No. 4464-23-7  
60 ○  キーワード ぎ酸カドミウム \$ ギ酸カドミウム \$ 蟻酸カドミウム \$ CADMIUM FORMATE  
 金属換算率 0.555

No. 対象  物質名 リン酸カドミウム  
 CAS No. 13477-17-3  
60 ○  キーワード リン酸カドミウム \$ リン酸カドミウム \$ 燐酸カドミウム \$ CADMIUM PHOSPHATE  
 金属換算率 0.64

# Substance Volume Totalization (image on screen)

**集計条件**

集計期間 2001年9月1日 ~ 2001年12月31日

職場グループ 日立製作所(大みか)

管理物質グループ 全ての物質

表示単位 0.00 kg 以上

**表示オプション**

簡易表示

---

ファイルダウンロード

集計データ

**Time Frame**

**Amt. Contained**

41件の物質が集計されました。

**Tetra-fluoro-ethane**

物質名 1,1,1,2-テトラフルオロエタン

CAS番号 811-97-2

**Material name**

**Process**

製品名	品目コード	事業所	使用職場	工程	納入日	含有量	単位
スプレーコン用ボンベ#500 500mlスプレー缶	S279001	日立製作所(大みか)	表面 化工課)	85000:塗装吹 き付け	2001/09/11	7.35	kg
スプレー 500mlス	1	日立製作所(大みか)	表面 課)	85000:塗装吹 き付け	2001/10/10	7.35	kg
スプレーコン用ボンベ#500 500mlスプレー缶	S279001	日立製作所(大みか)	表面 化工課)	85000:塗装吹 き付け	2001/10/18	7.35	kg
スプレーコン用ボンベ#500 500mlスプレー缶		日立製作所(大みか)	表面	85000:塗装吹	2001/12/26	11.03	kg
<b>小計</b>						33.07	kg

**Purchase Code**

**Workplace**

**Totalized Amount of Tetra-fluoro-ethane**

# Design for Environment

Design for Environment (DfE) or Environmental Conscious Design (ECD) is a concept of product design considering environmental impact through the life-cycle of a product. This "design" generally means all the decision making scenes of a production process including planning and procurement. Evaluation tools such as LCA are used.

Target Impact	Make Material	Make Parts	Distri- bution	Use	Recycle	Waste
Global Warming		○	○	○		
Resource Depletion	○			○	○	
Waste disposal	○	○		○		○
Hazardous Exposure		○		○		○

# DfE and Green Procurement

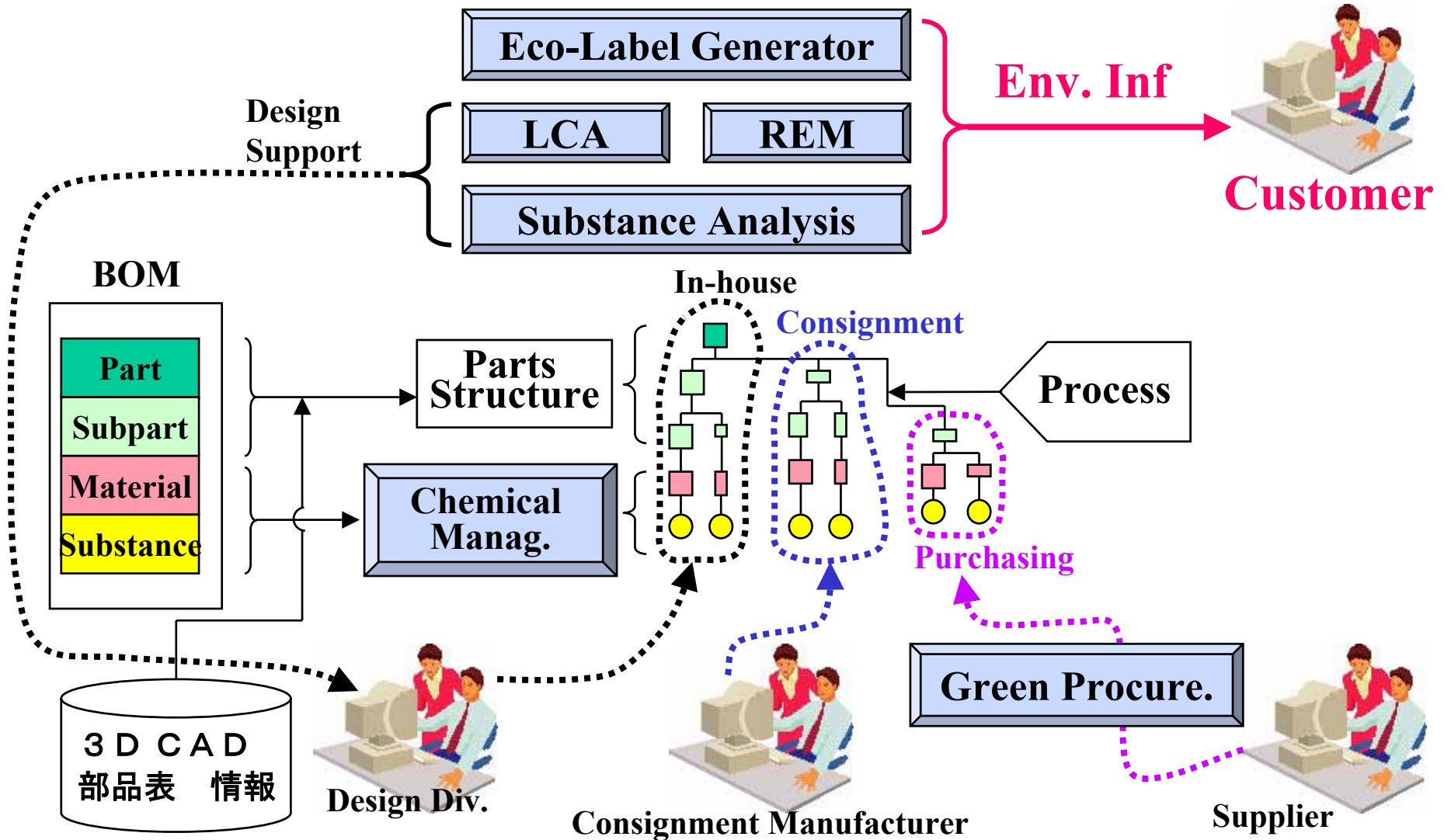

# Types and Volumes of Chemical Management Data

Case of a typical assembler type corporation

Type		Volume
Green Procurement	Suppliers	1,000 - 5,000
	Parts	10,000 - 100,000
Design Data	Materials	1,000
	All Parts	100,000 - 1,000,000
	Parts per product	1,000 - 10,000

# About BOM (Bill of Material)

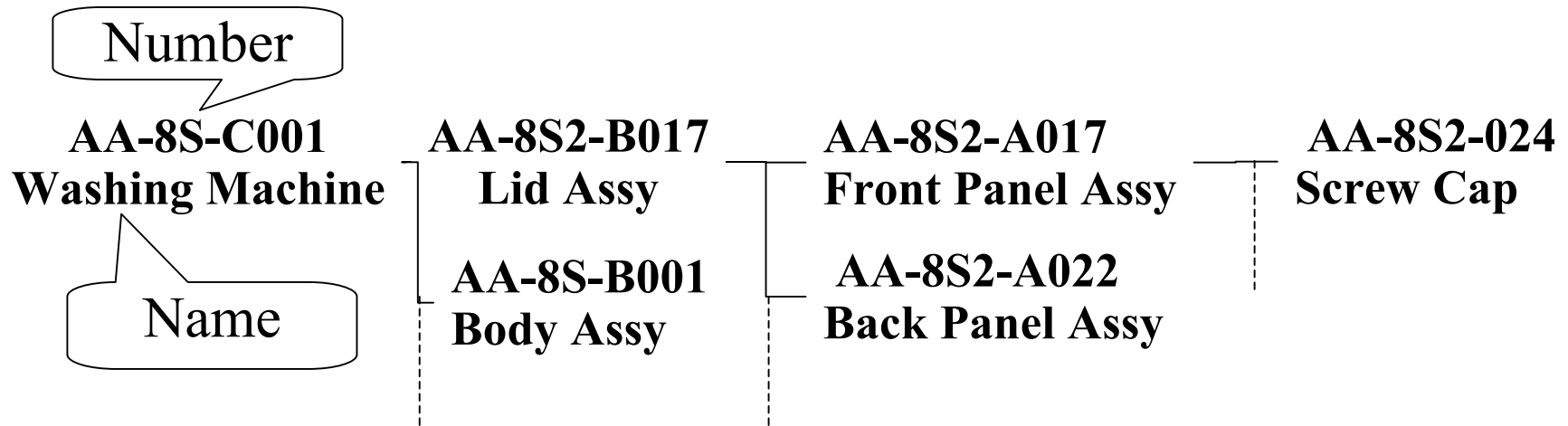

PN (Parts Name)

Number	Name
AA-8S-C001	Washing Machine
AA-8S2-B017	Lid Assy
AA-8S2-A017	Front Panel Assy

PS (Parts Structure)

Parent	Child	Count
AA-8S-C001	AA-8S2-B017	1
AA-8S-C001	AA-8S-B001	1
AA-8S2-B017	AA-8S2-A017	1

# Basic Data Structure for Substance Analysis

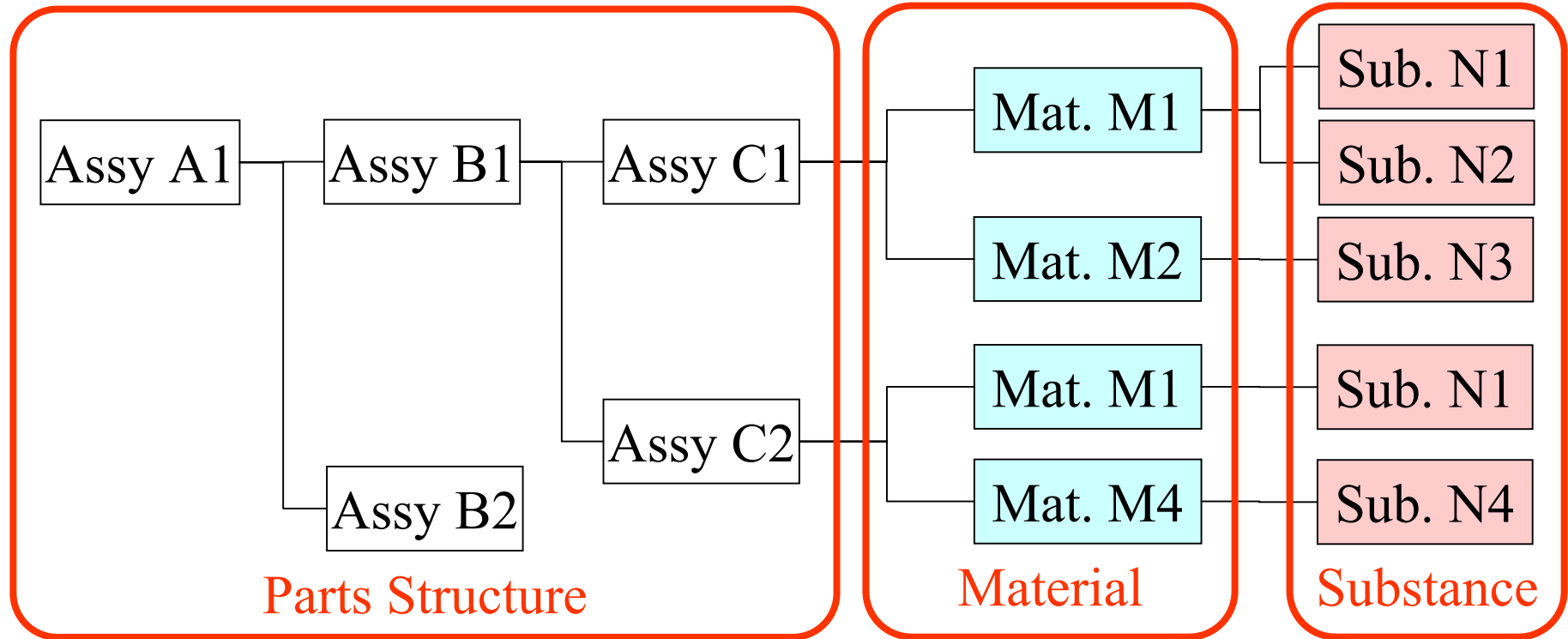

BOM

Green Procurement Information  
for Low-end Parts

# Basic Scheme of Green Procurement

## 1. Objective

Collect data on material and substance composition of low-end parts.

## 2. Means

Build a database with data registered by suppliers via Internet.

## 3. Substance Data

Substance is identified with CAS or Names. However both are not unique. Thus menu selection from a definition table of substances is preferred.

# Consideration of Green Procurement System

## Information Chaining along Supply Chain

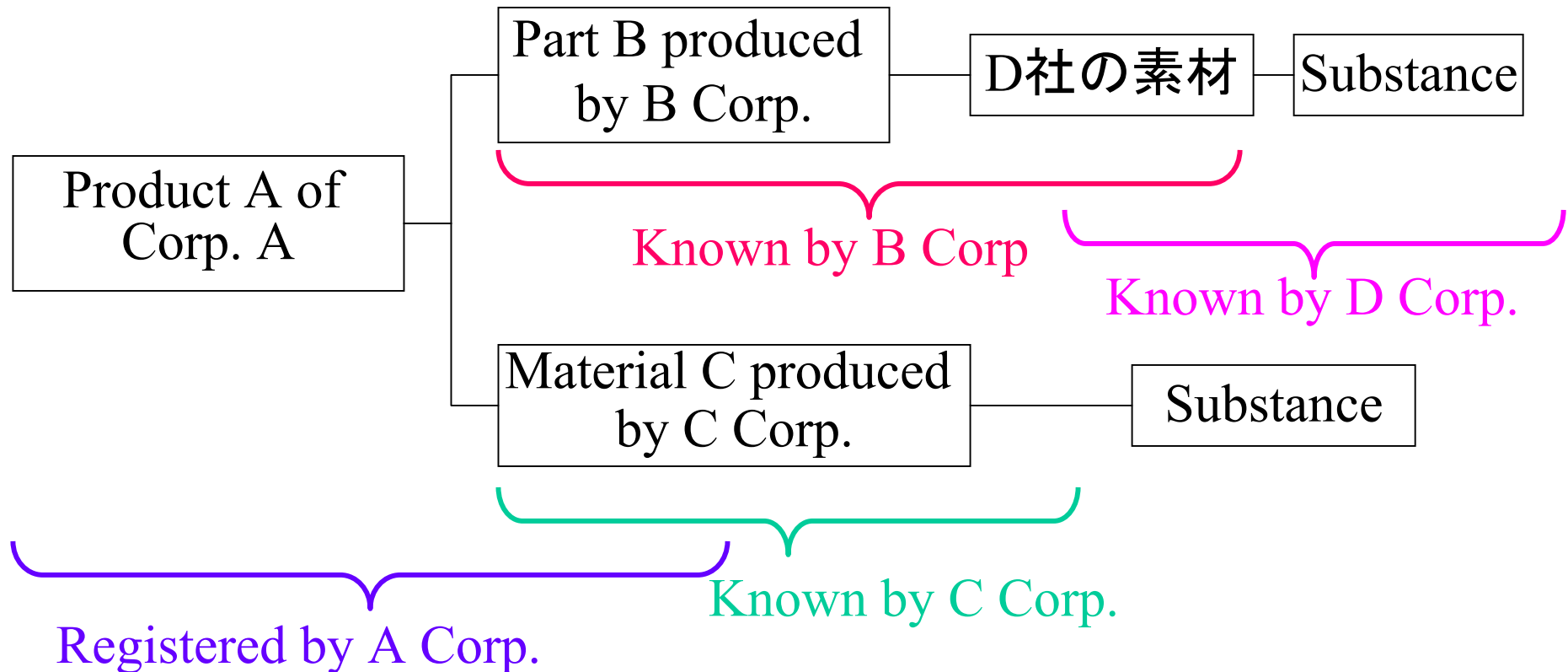

# Three Axes of Measuring Eco Maturity of Organization

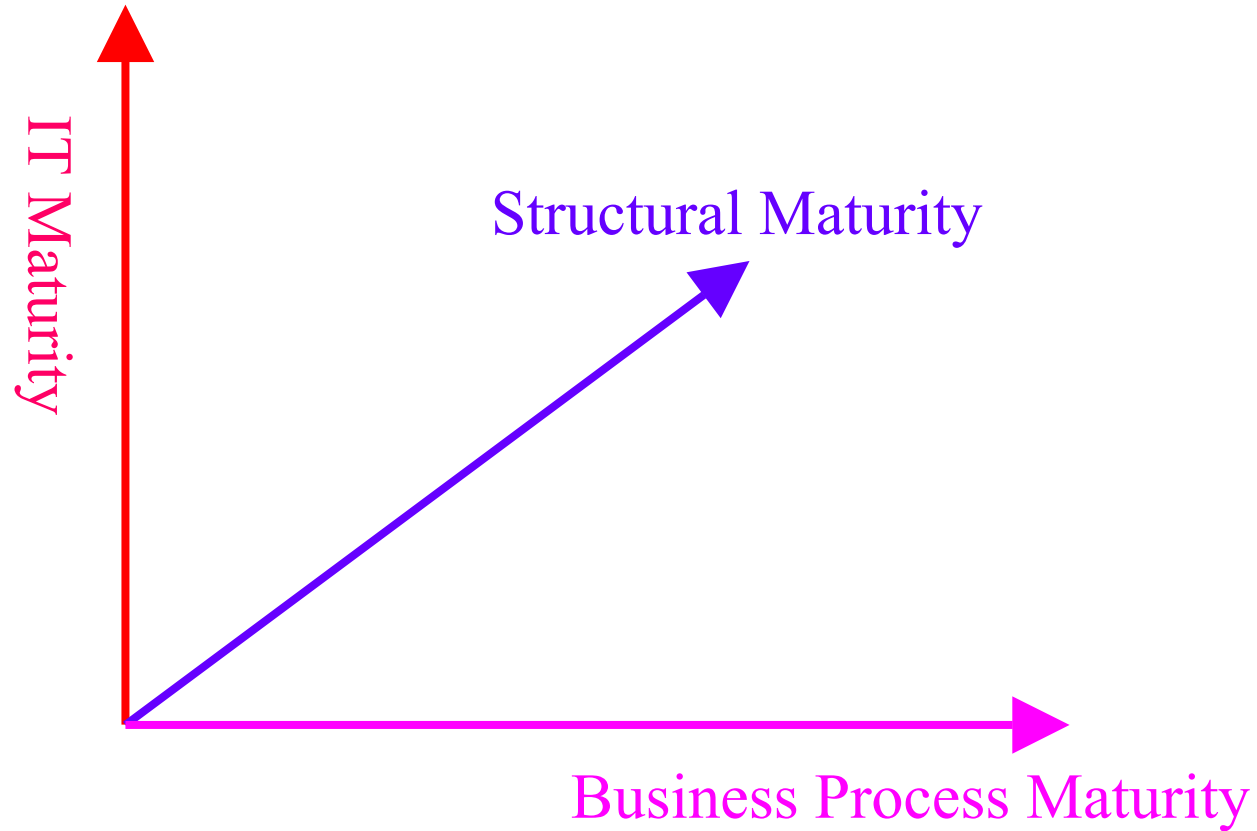

# Business Process Maturity Level

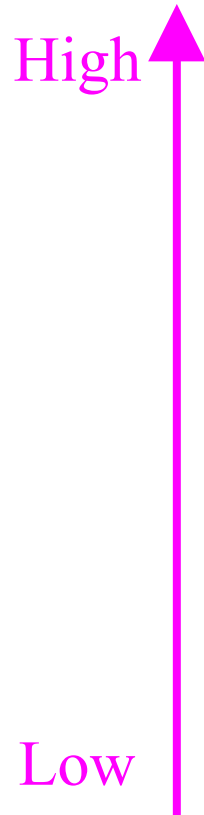
- 
- Able to evaluate all the products
  - Materials of different makers are individually identifiable even if they are same in the standard
  - Material information is written in parts list
  - Designers don't know the suppliers of their parts
  - Purchased parts IDs are not unique
  - DfE guideline is not issued

## Structural Maturity Level

High ↑  
↓  
Low

- Mutual data is shared and commonly managed with multiple divisions
- All designers conduct LCA
- There is a joint project with procurement, production, design, IT divisions
- Chemical Risk is independently managed by S&H and Environment people
- No Environmental Supervising Division in HQ

## IT Maturity Level

High

- Eco-Data is intercommunicated among a group companies including suppliers
- Eco-Data of all the facilities including overseas can be monitored at the HQ
- Common Database is shared by different jobs
- 3D cad system is used for design
- 10,000 excel sheets are accumulated through green procurement

Low

- Design data is on paper and not digitized